

ABOVE GROUND CARTRIDGE FILTER SYSTEMS

SYSTEMS INCLUDE

- Tank With Base
- 2-Speed Pump
- (2) Connection Hoses
- Adapters & Clamps
- 2 Slice Valves

- Timer
- Element
- Pressure Gauge
- Teflon Tape



STANDARD PLUG

AQUA PRO

CARTRIDGE FILTER SERIES

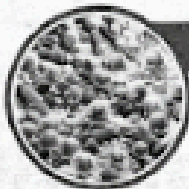

ANTI-MICROBIAL ELEMENTS

- ✓ Double the pleats of standard elements.
- ✓ Treated with anti-microbial silver-ions for superior filtration.

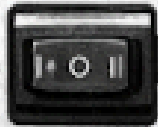

2-SPEED PUMPS

- ✓ 1 Speed / 2-Speed / OFF Switch options.



PLUG-IN TIMER



(2) SLICE VALVES



TANK SIZE

90 SQ.FT

120 SQ.FT

PUMP

1.5HP (1.5THP)

1.5HP (1.5THP)

Technical Data

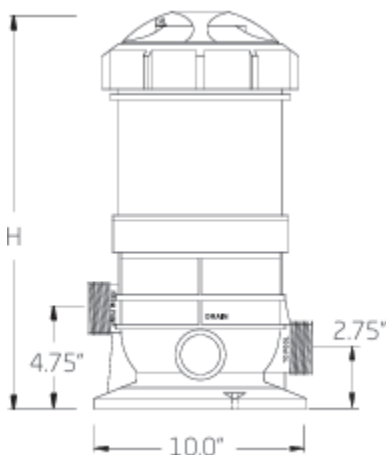

MODEL		90	120
FILTER AREA	sq. ft.	90	120
DIMENSIONS	H	28.0"	33.75"
MAXIMUM RECOMMENDED FLOW RATE*	GPM	90	120
MAXIMUM POOL CAPACITY	Gallons	43,000	57,000
PORT SIZE		1.5"	1.5"
MAXIMUM OPERATION PRESSURE	50 PSI		
MAXIMUM OPERATION TEMPARTURE	130 F		